

stap ①

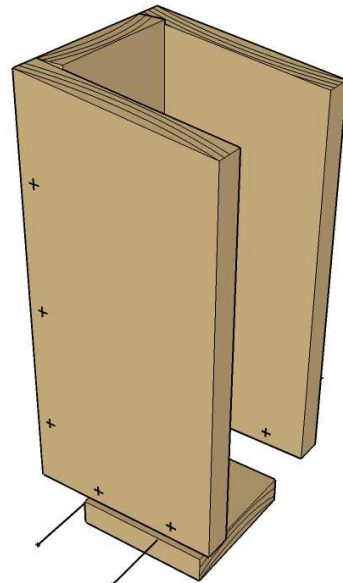

stap ②

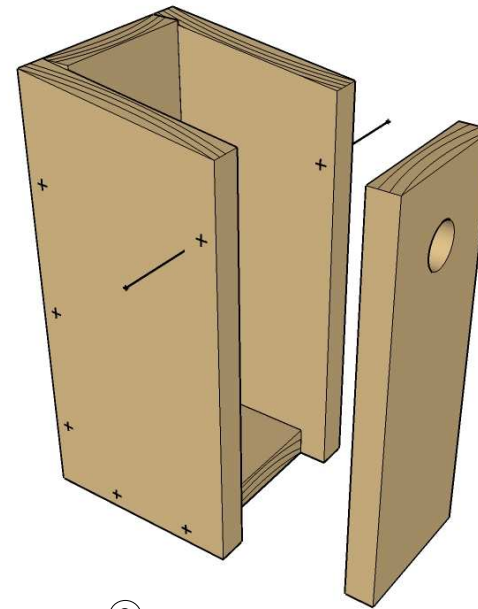

stap ③

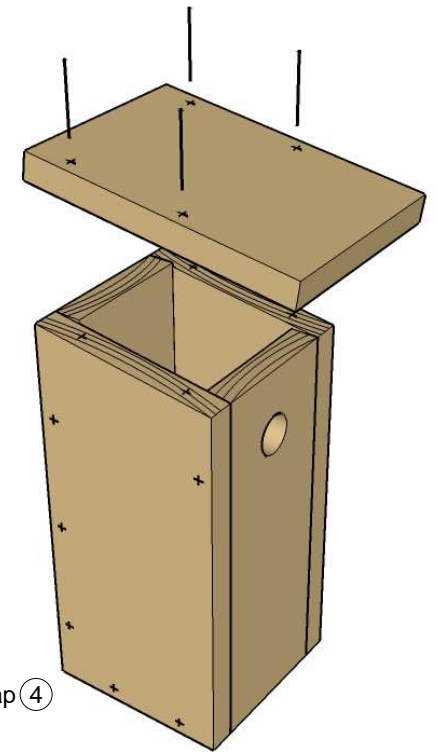

stap ④

- Leg de plankjes met de bolle kant naar binnen
- voordat u met spijkeren begint; plankjes op de zijkant leggen

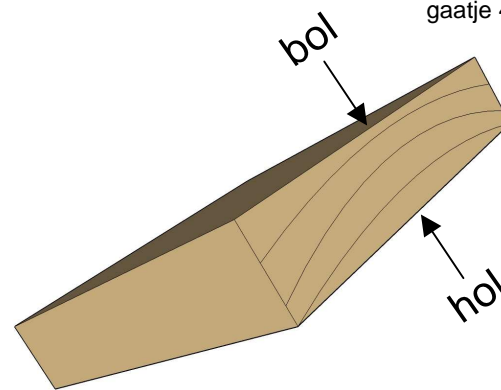
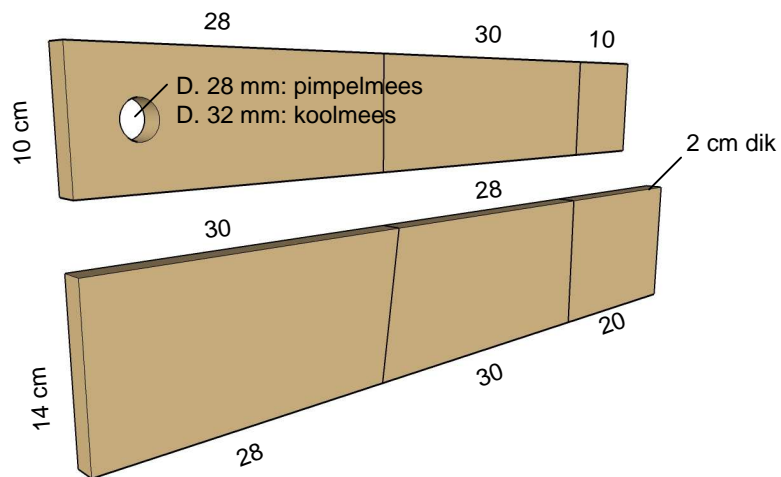

gaatje 4mm voor draad
rond boom

koperen spijker om te openen/reinigen
(voorboren)

